



# MAX7470 Evaluation Kit/Evaluation System

## General Description

The MAX7470 evaluation kit (EV kit) is a fully assembled and tested PC board that demonstrates the capabilities of the MAX7470 HDTV continuously variable anti-aliasing filter. The MAX7470 EV kit also includes Windows® 98SE/2000/XP-compatible software, which provides a simple graphical user interface (GUI) for exercising the MAX7470's features.

The MAX7470 evaluation system (EV system) includes a MAX7470 EV kit and a Maxim CMAXQUSB serial-interface board.

The CMAXQUSB board connects to a PC's USB port and allows the transfer of I<sup>2</sup>C commands to the MAX7470 EV kit.

The EV kit comes with the MAX7470UTP installed. The MAX7470 EV kit can also be used to evaluate the MAX7469. Contact the factory for free samples of the pin-compatible MAX7469UTP to evaluate this part.

*Windows is registered trademark of Microsoft Corp.*

## Component List

### MAX7470 EV System

PART	QTY	DESCRIPTION
MAX7470EVKIT	1	MAX7470 EV kit
CMAXQUSB	1	Serial-interface board

## Component Suppliers

SUPPLIER	PHONE	WEBSITE
Sanyo	619-661-6835	www.sanyo.com
TDK	847-803-6100	www.component.tdk.com

**Note:** Indicate you are using the MAX7470 when contacting these component suppliers.

## Features

- ◆ Continuously Variable Anti-Aliasing Filter  
5MHz to 34MHz in 256 Steps
- ◆ Supports All Standard Video Input Formats  
480i, 480p, 720p, 1080i  
YPbPr, RGB, Y/C, CVBS
- ◆ Accepts Any Input Sync Format  
Sync on Y, Sync on G, External Sync  
(Positive or Negative)  
Sync on All Channels
- ◆ Buffered Outputs Drive Standard 150Ω Video Load
- ◆ AC- or DC-Coupled Outputs with Jumper
- ◆ Controlled with USB
- ◆ Power-Down Mode
- ◆ Proven PC Board Layout
- ◆ Windows 98SE/2000/XP-Compatible Evaluation Software
- ◆ Fully Assembled and Tested

## Ordering Information

PART	DESCRIPTION	INTERFACE
MAX7470EVKIT	EV kit	User-supplied I <sup>2</sup> C interface
MAX7470EVCMAXQU	EV system	CMAXQUSB board

**Note:** The MAX7470 EV kit software is included with the MAX7470 EV kit but is designed for use with the complete EV system. The EV system includes both the Maxim CMAXQUSB board and the EV kit. If the Windows software will not be used, the EV kit board can be purchased without the Maxim CMAXQUSB board.

Evaluate: MAX7469/MAX7470

# MAX7470 Evaluation Kit/Evaluation System

## Component List (continued)

### MAX7470 EV Kit

DESIGNATION	QTY	DESCRIPTION
C1–C5	5	0.1µF ±15%, 16V X7R ceramic capacitors (0603) TDK C1608X7R1C104K
C6, C7	2	1µF ±15%, 16V X7R ceramic capacitors (0603) TDK C1608X7R1C105K
C8, C9, C10	3	220µF ±15%, 6.3V electrolytic capacitors (E7) Sanyo 6SVP220MX
JU1, JU2, JU3	3	3-pin single-row headers
JU4–JU7	4	2-pin single-row headers
IN1, IN2, IN3, EXTSYNC, OUT1, OUT2, OUT3	7	75Ω BNC female PC board mount jack connectors
J1	1	2 x 10 right-angle female receptacle connector
J2	0	Not installed
R1–R4, R7, R8, R9	7	75Ω ±1% resistors (0402)
R5, R6	0	Not installed (0603)
R10	1	0Ω resistor (0603)
U1	1	MAX7470UTP (20-pin TQFN)
—	7	Shunts
—	1	MAX7470 EV kit PC board

### MAX7470 EV Kit Files

FILE	DESCRIPTION
INSTALL.EXE	Installs the EV kit files on your computer
MAX7470.EXE	Application program
FTD2XX.INF	USB device driver file
UNINST.INI	Uninstalls the EV kit software
TROUBLESHOOTING_USB.PDF	USB driver installation help file

## Quick Start

### Recommended Equipment

- 5VDC power supply
- Video signal source
- HDTV monitor
- MAX7470 EV system
  - MAX7470 EV kit
  - Maxim CMAXQUSB board
  - USB cable (included with CMAXQUSB)
- A user-supplied Windows 98SE/2000/XP PC with a spare USB port
- Use the appropriate 75Ω BNC cables for the desired signal format.

**Note:** In the following section(s), software-related items are identified by bolding. Text in **bold** refers to items directly from the EV kit software. Text in **bold and underline** refers to items from the Windows 98SE/2000/XP operating system.

### Procedure

Do not turn on the power supply until all connections are complete.

- 1) Visit the Maxim website ([www.maxim-ic.com](http://www.maxim-ic.com)) to obtain the most recent revision of the EV kit software. Save the EV kit software to a temporary folder by unzipping the 7470Rxx.ZIP file.
- 2) Install the MAX7470 evaluation software on your computer by running the INSTALL.EXE program inside the temporary folder. The program files are copied and icons are created in the Windows **Start** menu.
- 3) On the CMAXQUSB board, ensure shunt JU1 is in the 3.3V position.
- 4) Enable the I<sup>2</sup>C pullup resistors on the CMAXQUSB board by setting the DIP switches SW1 to the on position.
- 5) For the MAX7470 EV kit, move JU3 in the 1-2 position only after first completing steps 1 and 2. Verify all other jumpers are in their default positions as shown in Tables 2–5.
- 6) Carefully connect the boards by aligning the MAX7470 EV kit's 20-pin connector with the 20-pin header of the CMAXQUSB board. Gently press them together. The two boards should be flush against each other.
- 7) Connect 75Ω BNC cables between the video-signal source's outputs and the MAX7470 EV kit's inputs (IN1, IN2, IN3), and connect 75Ω BNC cables from the MAX7470 EV kit's outputs (OUT1, OUT2, OUT3) to the HDTV monitor's inputs. Configure the MAX7470, depending on the format of the input signal, according to Table 1.

# MAX7470 Evaluation Kit/Evaluation System

**Table 1. Input and Output Channel Configuration**

VIDEO-SIGNAL FORMAT	IN1/OUT1	IN2/OUT2	IN3/OUT3
CVBS, Y, C	CVBS	Y	C
Y, Pb, Pr	Y	Pb	Pr
Gs, B, R	Gs	B	R
G, B, R, H, V	G	B	R

8) If the G, B, R, H, V video format is used, put a T-connector on the H-sync output of the video signal source. Using one 75Ω BNC cable, connect the T-connector to the MAX7470 EV kit's EXTSYNC connector. Using one 75Ω BNC cable, connect the T-connector to the H-sync input of the HDTV monitor. Using one 75Ω BNC cable, connect the V-sync output of the video signal source to the V-sync input of the HDTV monitor.

- 9) Connect the 5VDC power supply between the MAX7470 EV kit's AVDD and AGND pads.
- 10) Turn on the 5VDC power.
- 11) Connect the USB cable from the PC to the CMAXQUSB board. A **Building Driver Database Found** message if this is the first time this board is connected to the PC. If you do not see a window that is similar to the one described above after 30 seconds, try removing the USB cable from the CMAXQUSB and reconnect it. Administrator privileges are required to install the USB device driver on Windows 2000 and XP. Refer to the TROUBLESHOOTING\_USB.PDF document included with the software for more information.

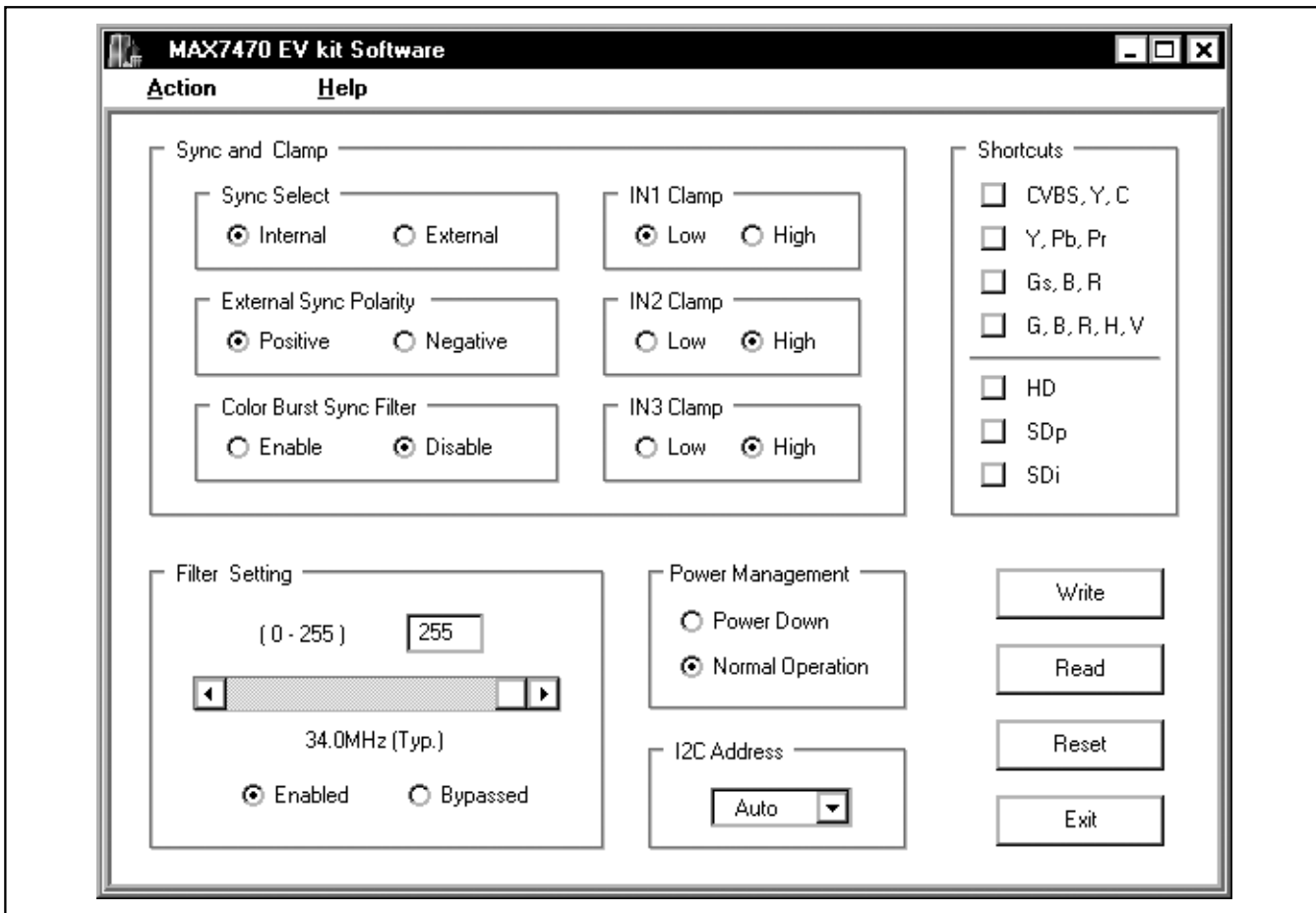

Figure 1. MAX7470 EV Kit Software GUI Window

# MAX7470 Evaluation Kit/Evaluation System

- 12) Follow the directions of the **Add New Hardware Wizard** to install the USB device driver. Choose the **Search for the Best Driver for your Device** option. Specify the location of the device driver to be **C:\Program Files\MAX7470** (default installation directory) using the **Browse** button.
- 13) Start the MAX7470 EV kit software by opening its icon in the **Start** menu.
- 14) Depending on the video-signal format, press the desired shortcut buttons inside the **Shortcuts** group box to make the appropriate settings. The video image generated by the video-signal source appears on the HDTV monitor's screen.

## Detailed Description of Software

To start the MAX7470 EV kit software, open the MAX7470 EV kit icon that is created during installation. The GUI shown in Figure 1 appears. The user has to wait approximately 2 seconds while the MAX7470 EV kit software detects the CMAXQUSB board.

### Shortcuts Group Box

The **Shortcuts** group box shown in the top-right corner of Figure 1 contains seven different preset combinations of sync, clamp, and the filter's cutoff frequency for various video-signal formats. These shortcuts are provided for convenience so the user can quickly configure the MAX7470. There are four shortcuts for the sync and clamp combinations. They are **CVBS, Y, C; Y, Pb, Pr; Gs, B, R;** and **G, B, R, H, V**. There are three shortcuts to set the cutoff frequency of the filter. They are **HD, SDp** (progressive scan), and **SDi** (interlaced).

### Sync and Clamp Group Box

The **Sync and Clamp** group box shown in the top-left corner of Figure 1 allows the user to choose the sync selection, external sync polarity selection, enable/disable the color-burst sync filter, and change the clamp level for all three channels.

### Filter Setting Group Box

The **Filter Setting** group box in the bottom-left corner of Figure 1 allows the user to choose the desired cutoff frequency or bypass the filter.

### Power-Management Group Box

The **Power Management** group box allows the user to put the MAX7470 in normal operation or power-down mode.

**Table 2. I<sup>2</sup>C Address Configuration**

JU2	JU1	I <sup>2</sup> C ADDRESS
1-2*	1-2*	1001011x
1-2	2-3	1001010x
2-3	1-2	1001001x
2-3	2-3	1001000x

\*Default position.

### I<sup>2</sup>C Address Pulldown Menu

The software autodetects the MAX7470's I<sup>2</sup>C slave address as shown in the **I<sup>2</sup>C Address** pull-down menu. If multiple devices are connected to the I<sup>2</sup>C bus, the user can use this pull-down menu to manually change the device's I<sup>2</sup>C slave address according to the settings of JU1 and JU2 as shown in Table 2.

### Write, Read, Reset, and Exit Buttons

There are four buttons in the bottom-right corner of the MAX7470 EV kit software GUI window as shown in Figure 1. They are **Write, Read, Reset,** and **Exit**.

Except for the I<sup>2</sup>C address, whenever the settings in the MAX7470 EV kit software GUI window have been changed, the user must press the **Write** button to send the software settings to the hardware. The **Write** button is disabled (grayed out) after being pressed, and is enabled again when a setting has been modified.

The **Read** button reads the current hardware settings and updates the MAX7470 EV kit software GUI window. The **Write** button is disabled (grayed out) after the **Read** button has been pressed.

Press the **Reset** button to reset the hardware and the MAX7470 EV kit software GUI window to the default settings. The **Write** button is disabled (grayed out) after the **Reset** button has been pressed. Pressing the **Reset** button does not require a subsequent pressing of the **Write** button.

Press the **Exit** button to quit the MAX7470 EV kit software.

# MAX7470 Evaluation Kit/Evaluation System

## Detailed Description of Hardware

The MAX7470 EV kit board provides a proven layout for evaluating the MAX7470. The EV kit comes with the MAX7470UTP installed.

### Power Supplies

The analog portion of the MAX7470 must be powered by a user-provided 5V power supply connecting to AVDD. The digital portion of the MAX7470 can be powered from either the CMAXQUSB or from a user-provided 3.3V power supply connecting to DVDD, as shown in Table 3. Verify the CMAXQUSB jumper JU1 is in the 3.3V position.

**Table 3. DVDD Selection Configuration**

JUMPER	SHUNT POSITION	DESCRIPTION
JU3	1-2	Powered by CMAXQUSB.
	2-3*	Powered by a user-provided 3.3V power supply.

\*Default position.

### Input Channels

All three input channels (IN1/IN2/IN3) are terminated with 75Ω resistors and AC-coupled. The external sync input (EXTSYNC) is DC-coupled and can be terminated with a 75Ω resistor as shown in Table 4.

**Table 4. EXTSYNC Input Terminator Configuration**

JUMPER	SHUNT POSITION	DESCRIPTION
JU4	1-2*	EXTSYNC is terminated with a 75Ω resistor.
	Open	EXTSYNC is not terminated.

\*Default position.

### Output Channels

All three output channels (OUT1/OUT2/OUT3) can be both AC- or DC-coupled as shown in Table 5.

**Table 5. Output Channel Configuration**

JUMPER	SHUNT POSITION	DESCRIPTION
JU5	Open*	OUT1 is AC-coupled.
	1-2	OUT1 is DC-coupled.
JU6	Open*	OUT2 is AC-coupled.
	1-2	OUT2 is DC-coupled.
JU7	Open*	OUT3 is AC-coupled.
	1-2	OUT3 is DC-coupled.

\*Default position.

### Grounding

The MAX7470 EV kit's analog ground AGND and digital ground DGND are connected together through a 0Ω resistor, R10. If desired, the user can separate these two grounds by removing R10.

### User-Supplied I<sup>2</sup>C Interface

To use the MAX7470 EV kit with a user-supplied I<sup>2</sup>C interface, install the shunt on jumper JU3's 2-3 position. Connect SDA, SCL, and GND lines from the user-supplied I<sup>2</sup>C interface to the corresponding pins of J2 on the MAX7470 EV kit. Apply a 3.3V power supply to the DVDD and DGND pads of the MAX7470 EV kit. Depending on the configuration of the user-supplied I<sup>2</sup>C interface, it may be necessary to install the I<sup>2</sup>C pull-up resistors R5 and R6.

Evaluate: MAX7469/MAX7470

# MAX7470 Evaluation Kit/Evaluation System

**Evaluate: MAX7469/MAX7470**

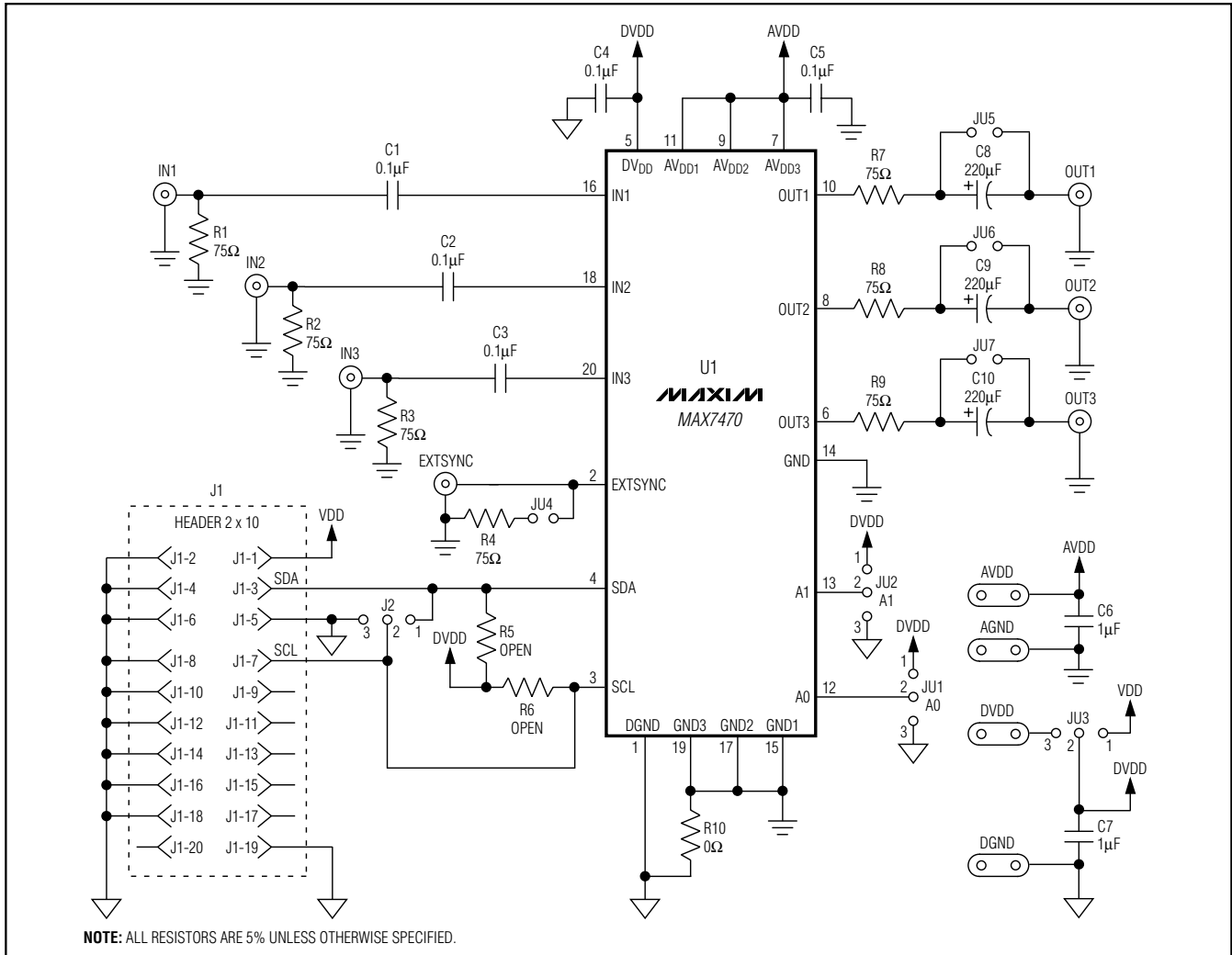

Figure 2. MAX7470 EV Kit Schematic

# MAX7470 Evaluation Kit/Evaluation System

Evaluate: MAX7469/MAX7470

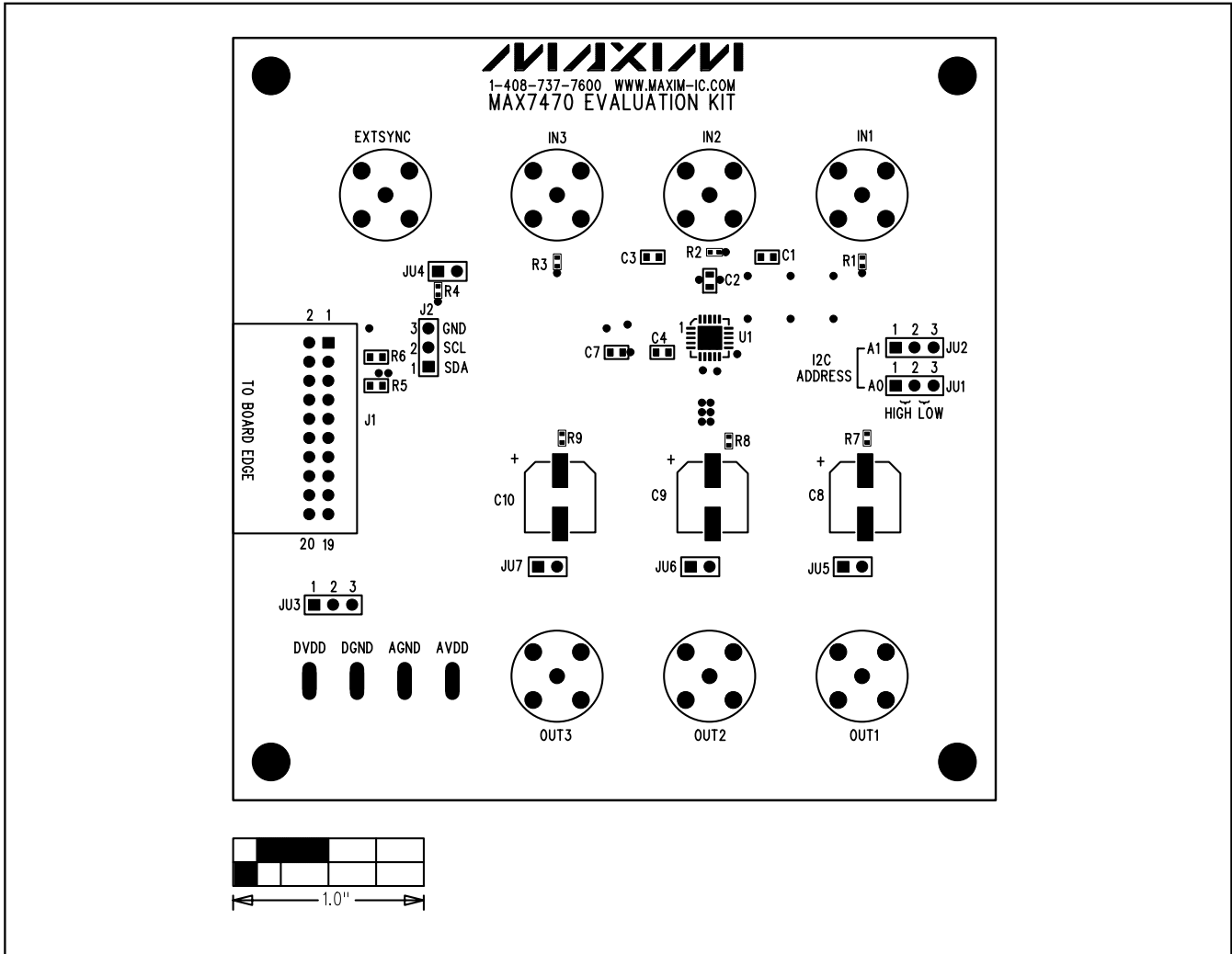

Figure 3. MAX7470 EV Kit Component Placement Guide—Component Side

# MAX7470 Evaluation Kit/Evaluation System

Evaluate: MAX7469/MAX7470

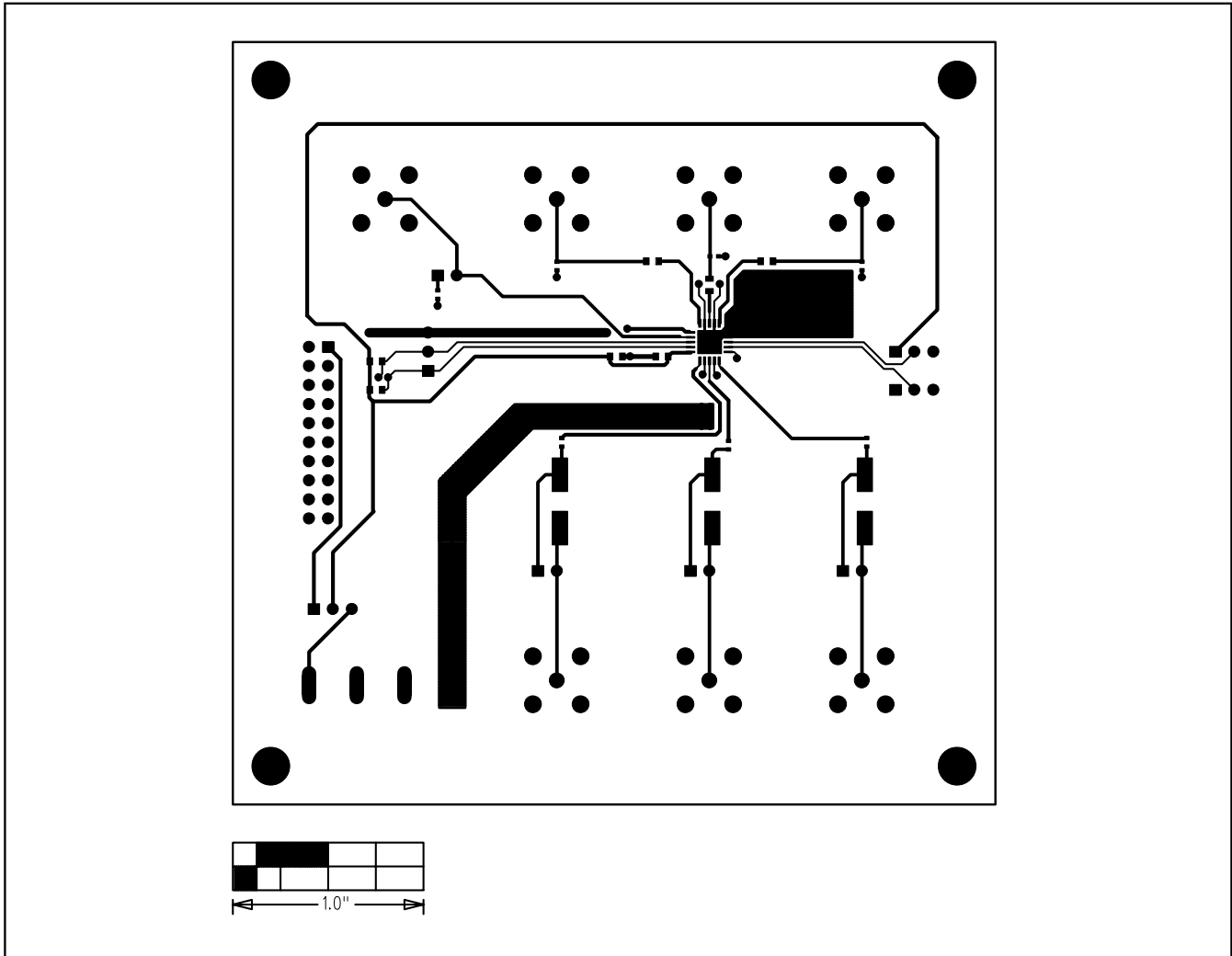

Figure 4. MAX7470 EV Kit PC Board Layout—Component Side



# MAX7470 Evaluation Kit/Evaluation System

Evaluate: MAX7469/MAX7470

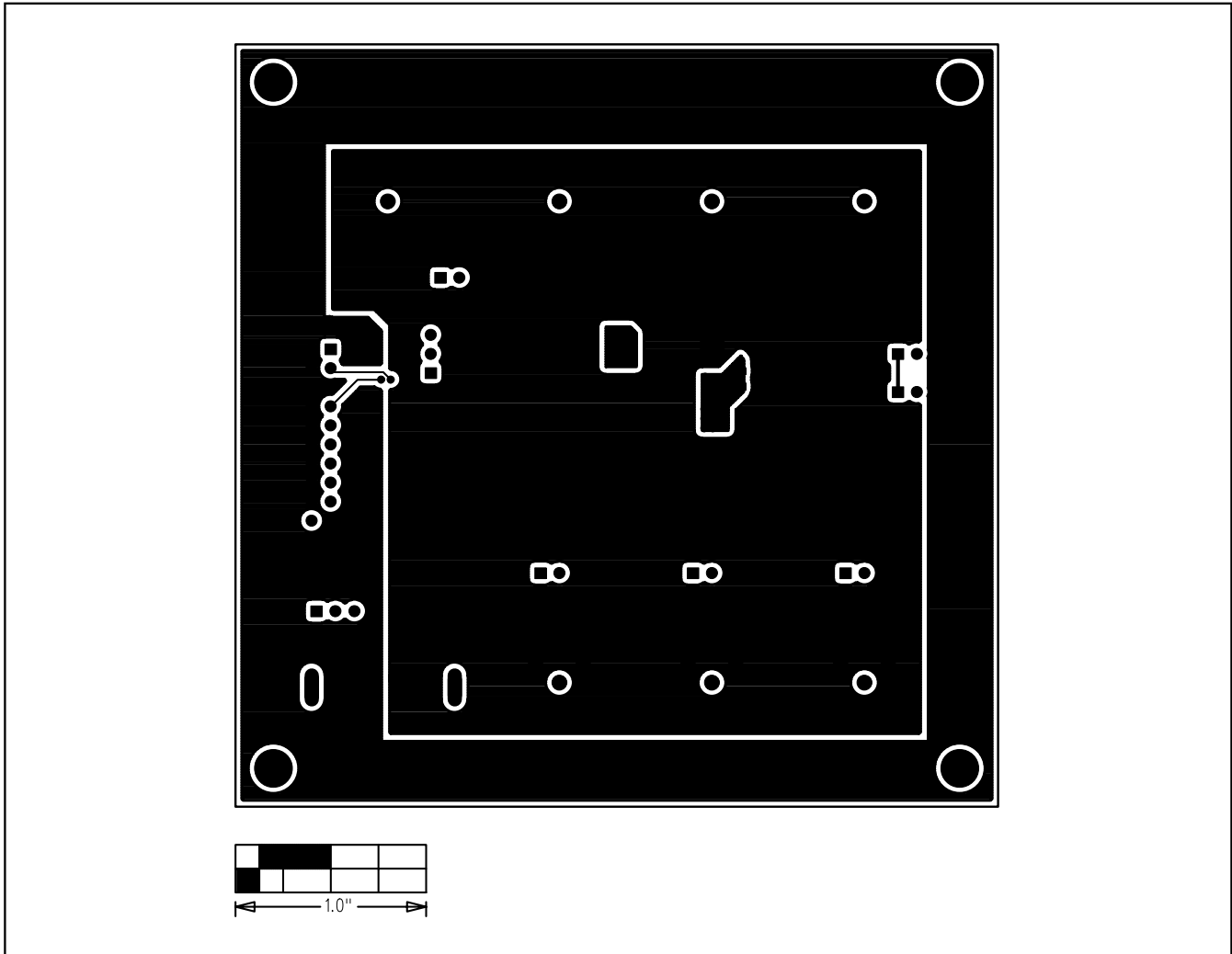

Figure 5. MAX7470 EV Kit PC Board Layout—Solder Side

# MAX7470 Evaluation Kit/Evaluation System

Evaluate: MAX7469/MAX7470

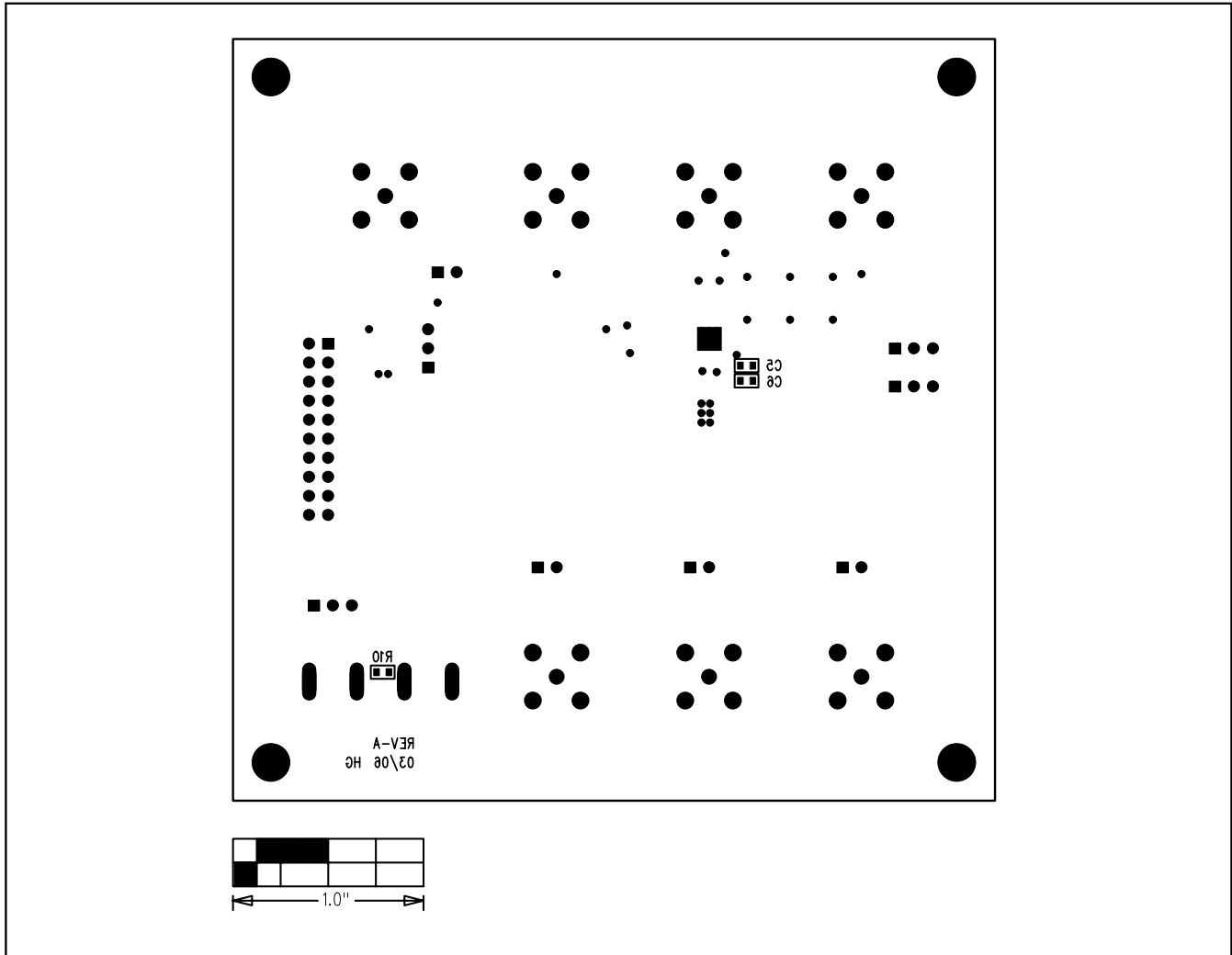

Figure 6. MAX7470 EV Kit Component Placement Guide—Solder Side

Maxim cannot assume responsibility for use of any circuitry other than circuitry entirely embodied in a Maxim product. No circuit patent licenses are implied. Maxim reserves the right to change the circuitry and specifications without notice at any time.

10 **Maxim Integrated Products, 120 San Gabriel Drive, Sunnyvale, CA 94086 408-737-7600**